

»FUTURA« series

The filling unit protects devices connected downstream by ensuring a gradual build-up of pressure. The unit consists of a 3/2-way valve including silencer and a filling valve (start-up valve). It is connected and disconnected by means of the 3/2-way valve. The filling time can be altered by turning the adjusting screw.

Input pressure	2.5 - 16 bar
Temperature range	-10 °C to 50 °C
Medium	Compressed air, neutral gases
Housing	PA66 GF60
Connecting thread	Material: Die-cast zinc
Flow rate measurement	At P ₂ = 6 bar and pressure drop Δ _p = 1 bar

Filling unit, pneumatically operated, adjustable filling time

Art. No.	Type No.	Thread	Size	Exhaust air	Flow rate l/min
156636	FU 994-137	G 3/4	4	G 1/2	9000
156637	FU 995-137	G 1	4	G 1/2	9000

Accessories / Spare parts

Art. No.	Type No.	Description
100048	H 854	Mounting bracket, incl. 2 screws
100049	WK 103	Wall bracket, incl. 2 screws
100050	KP 300	Joiner set, incl. 2 screws
100293	567-5/M	Silencer, sintered bronze, with brass hexagon nut and thread
135853	WK 104-34	Wall bracket with connection thread G 3/4
135854	WK 104-1	Wall bracket with connection thread G 1

P 1-496 e

Filling unit
pneumatically operated
Art. No. 156636 and 156637

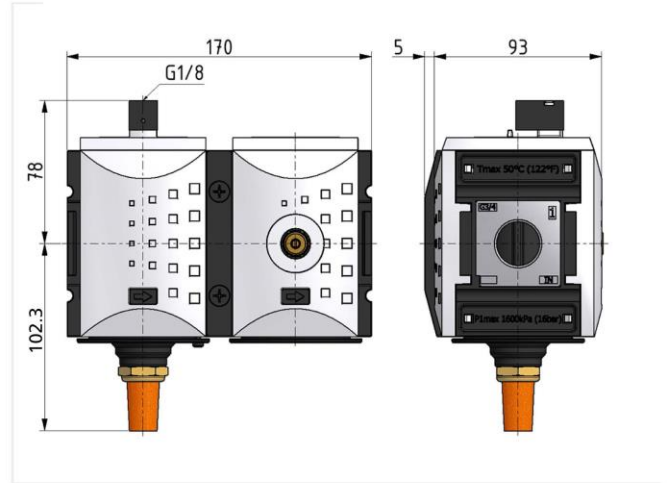

flow characteristic

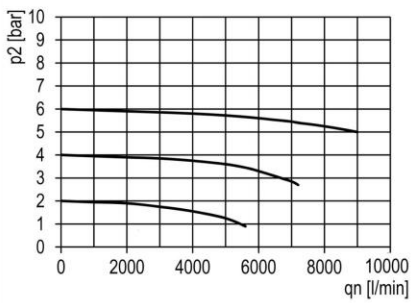

symbol

